

VDH SMALL PILING HAMMERS 500 T/M 2500 KG

In addition to selling equipment, Van den Heuvel (VDH) is perfectly capable of designing and building high-quality machines. Van den Heuvel has a lot of experience developing and constructing piling hammers, both large and small. This product sheet covers the small hammers with a drop weight of 500 to 2500 kg. The hammers are round, have low installation dimensions and are lightweight.

ROBUST, SIMPLE, RELIABLE

VDH piling hammers have been around for a long time and are, in fact, simple yet efficient hammers. Based on years of expertise and the necessary practical and customer experience, VDH has continuously developed its piling hammers. As a result, the quality has continuously improved and the hammers are extremely reliable. With a view to the future, Van den Heuvel has begun developing noise-reducing hammers, in response to increasing market demand for quieter piling hammers.

FOR SMALL FOUNDATION OR EXCAVATION MACHINES

VDH's small hammers have two cylinders on the outside for a lower drop weight. This makes the hammers ideally suited for lighter work, such as driving wooden piles or installing short piles. Ideal for contractors working with small foundation piling machines or an excavator, with which the hammer can also be used.

LONG TOOL LIFE, FIELD REPAIRABLE

A big advantage of the small hammers is that they have a long tool life and require few repairs. And if repair should ever be needed, it does not have to be done in the workshop – it can be done out in the field. Based on practical experience, the frame has been developed in such a way that the change of hammer cylinders, hoses and accumulators can be done on location. This makes it quick and easy to carry out a repair, which is also more cost-effective.

PRODUCTION IN OUR WORKSHOPS

In our fully equipped metal and hydraulic workshops and paint shop, we employ skilled welders, mechanics and paint sprayers who ensure that you get a top-notch end product. The welding, hydraulics and assembly of the piling rigs and appliances are all completed here. The piling rigs and appliances are then treated in our paint shop to preserve them.

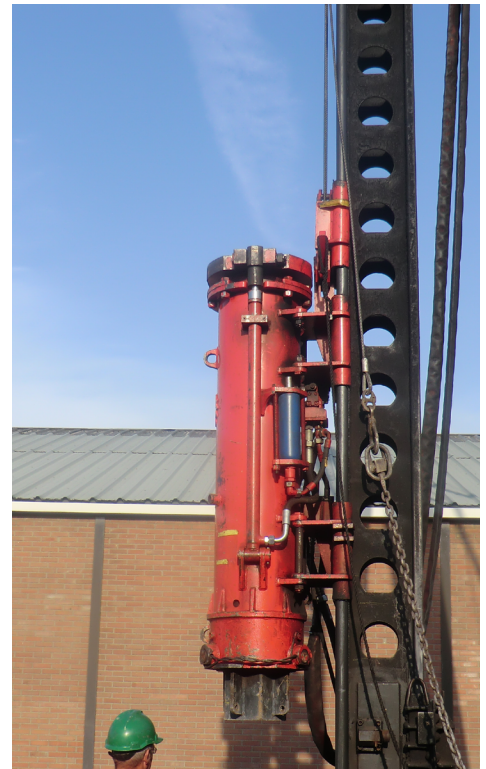

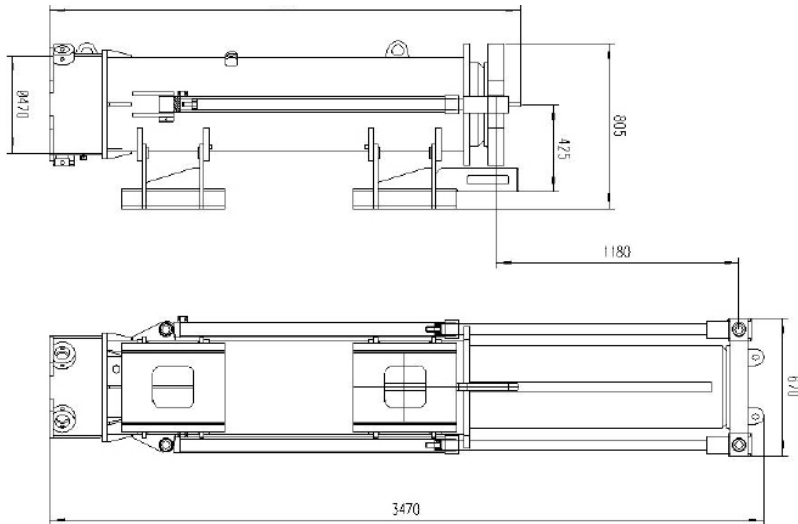

BENEFITS OF THE VDH SMALL PILING HAMMERS – 500 TO 2500 KG:

- Efficient, simple hammer
- High reliability
- Lightweight
- Free-fall cylinders (less oil needed)
- Fixed installation
- Long tool life
- Field repairable

All VDH machines are extensively and carefully tested and approved prior to delivery, are of the highest quality and meet the applicable standards. Van den Heuvel also provides maintenance and service for all the machines.



READY FOR THE FUTURE

Van den Heuvel designs, modifies and builds various types of high-quality machines for special applications. VDH is therefore a successful partner in the foundation sector. Production and modification take place entirely in-house, using state-of-the-art equipment, with expertise developed over many years. Everything is taken care of for the customer throughout the process, from the initial request to delivery of the machine, service and maintenance. Custom solutions result in perfect basic machines, which can be adapted to the needs of the customer or project.

