

VDH MULTIPURPOSE FOUNDATION PILING MACHINE MP70

Each project is unique and has its own foundation requirements. Therefore, Van den Heuvel developed its own line of modular multipurpose machines, which can be used for a wide range of foundation work, such as drilling, compacting, vibrating and pile driving. The VDH-MP60 was initially developed based on a specific customer requirement. This was followed by the MP40 and MP70.

VDH-MP70: FLEXIBLE LEADER LENGTH

The VDH-MP70 is the third machine in the range and a further development of the previous two variants. The MP70 is flexible in terms of its leader length and attachments, making it suitable for many types of work. This is because the MP70 is equipped with a special rack and pinion system.

The big advantage of this is that winches are no longer needed and the leader can be easily shortened. This makes it the ideal solution for projects in the city centre, work in buildings or for use under high-voltage pylons. The variant with a long leader (29 metres) has the inclination cylinders at the back. Gripping the leader at a higher point results in greater the leader stability. The shortest version (25 metres) is basically the same, but shorter, making it easier to work under high-voltage pylons or inside buildings.

QUICK-CHANGE SYSTEM

A further advantage of the rack and pinion system is that it drives the quick-change plate at the front of the leader. This quick-change system makes it very simple to change attachments: from compaction block to piling hammer and drilling unit.

When developing this machine, Van den Heuvel went beyond the drawing board. In order to best meet all the wishes and requirements from the market, Van den Heuvel involved both customers and technicians in the process. This ensures that the machine is optimally configured for everyone involved.

TECHNICAL INNOVATIONS

The high efficiency of the machine is achieved by the reliability and quality of the brands, materials and components used. The MP70 has a heavy duty engine and large pumps, which means plenty of power and lots of oil to drive the attachments.

Like its little brothers, the MP70 is built with a passion for technical innovation. This means it is optimally matched to the way the customer works, for greater efficiency and effectiveness.

The operator's cabin is noise and vibration damped and equipped with fan, heater and air conditioning. The MP70 has two hydraulically extendible outriggers mounted at the rear of the machine, alongside the ballast weight. The undercarriage of the machine can be hydraulically widened to a maximum outer dimension of 4,900 mm.



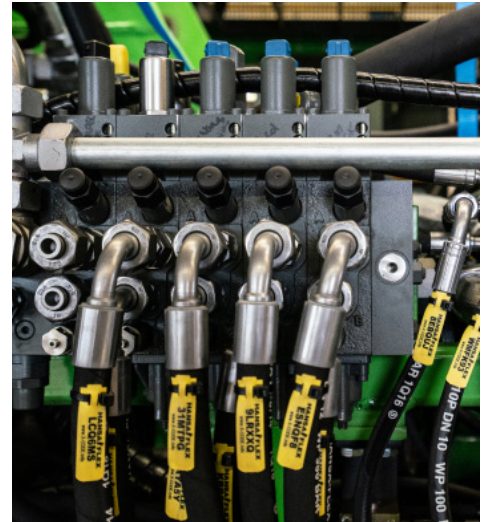
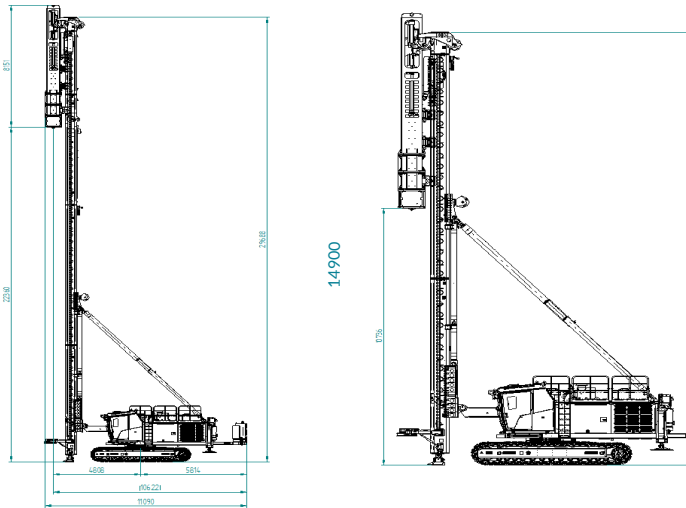

ADVANTAGES OF THE MP70:

- Multipurpose, modular design
- Flexible leader length (up to 29 metres)
- Special rack and pinion system
- High efficiency, high stability
- Hydraulically adjustable undercarriage
- Safe, efficient operation
- CE certified and compliant following standard NEN-EN 16228
- Configurable to customer requirements

All VDH machines are extensively and carefully tested and approved prior to delivery, are of the highest quality and meet the applicable standards. Van den Heuvel also provides maintenance and service for all the machines.



READY FOR THE FUTURE

Van den Heuvel designs, modifies and builds various types of high-quality machines for special applications. VDH is therefore a successful partner in the foundation sector. Production and modification take place entirely in-house, using state-of-the-art equipment, with expertise developed over many years. Everything is taken care of for the customer throughout the process, from the initial request to delivery of the machine, service and maintenance. Custom solutions result in perfect basic machines, which can be adapted to the needs of the customer or project.

