

MULTIPURPOSE FOUNDATION PILING MACHINE MP40

Each project is unique and has its own foundation requirements. Therefore, Van den Heuvel developed its own line of modular multipurpose machines, which can be used for a wide range of foundation work, such as drilling, compacting, vibrating and pile driving. It started with the VDH-MP60, developed on the basis of a specific customer request. This was followed by the MP40 and MP70.

VDH-MP40

The MP40 is built as a 40 tonne basic machine and, depending on which attachment is used, can be used as a ground screw and pile driving machine. When developing this machine Van den Heuvel went beyond the drawing board. In order to best meet all the wishes and requirements from the market, Van den Heuvel involved both customers and technicians in the process. This ensures that the machine is optimally configured for everyone involved. The MP40 is more compact than its 'big brothers', the MP60 and MP70. The machine can be transported with the drill box and drills, which makes it ideal for working on several smaller projects per day.

TECHNICAL INNOVATIONS

The MP40 is built to be simple and efficient. The high efficiency of the machine is achieved by the reliability and quality of the brands, materials and components used. The MP40 is built with a passion for technical innovation. This means it is optimally matched to the way the customer works, for greater efficiency and effectiveness.

MODULAR MACHINE

The modular machine serves as a solid base that allows complete flexibility in how it is prepared and automated, to perfectly match the customer's wishes. This allows variation within the standard components in terms of motor power, pump, leader and ballast. The machine is therefore optimally suited to specific types of work within the sector. The machine can also be painted in the desired colours.

PRODUCTION IN OUR WORKSHOPS

In our fully equipped metal and hydraulic workshops and paint shop, we employ skilled welders, mechanics and paint sprayers who ensure that you get a top-notch end product. The welding, hydraulics and assembly of the piling rigs and appliances are all completed here. The piling rigs and appliances are then treated in our paint shop to preserve them.

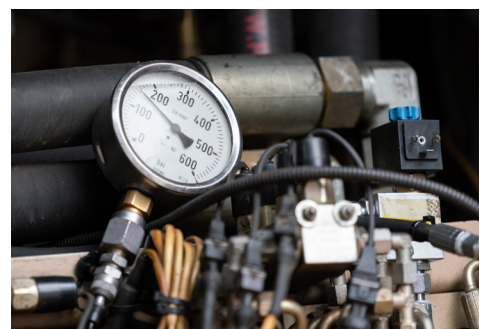
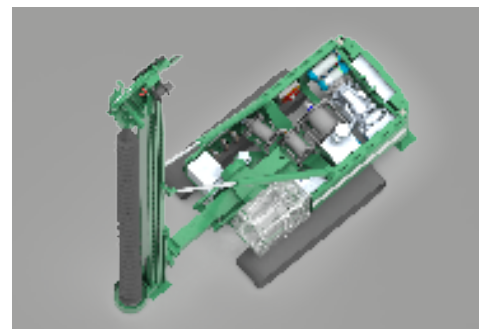
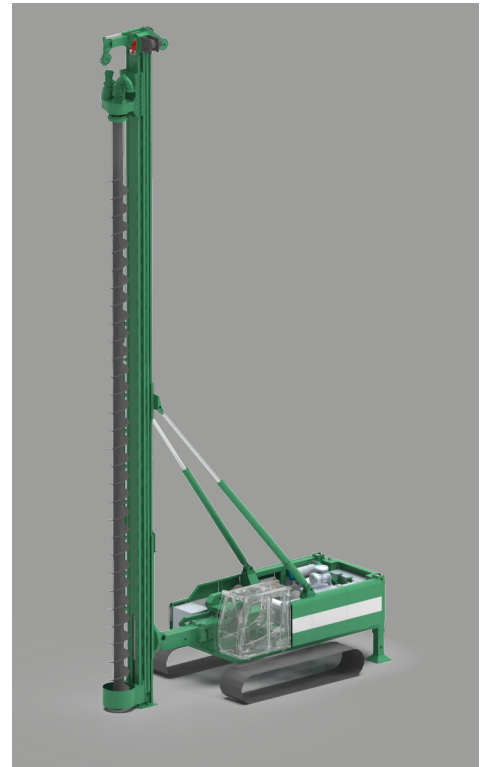

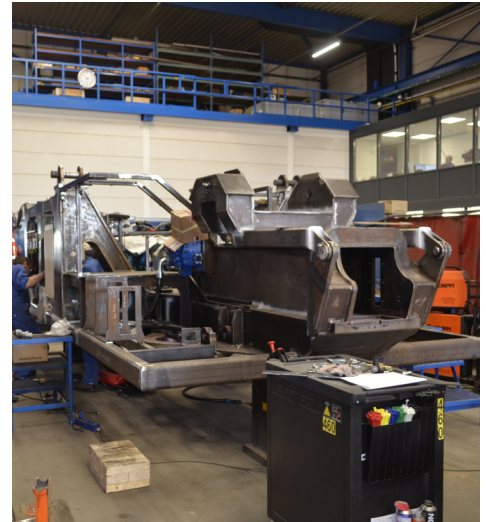
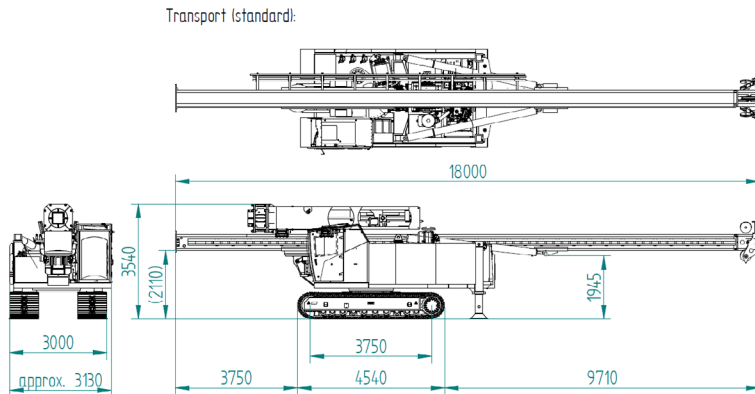

ADVANTAGES OF THE MP40:

- Multipurpose
- Modularly constructed
- High efficiency
- Hydraulically adjustable undercarriage
- Compact for transport (3,100 mm by 18,000 mm)
- Safe, efficient operation
- CE certified and compliant with foundation standard
NEN-EN 16228

All VDH machines are extensively and carefully tested and approved prior to delivery, are of the highest quality and meet the applicable standards. Van den Heuvel also provides maintenance and service for all the machines.

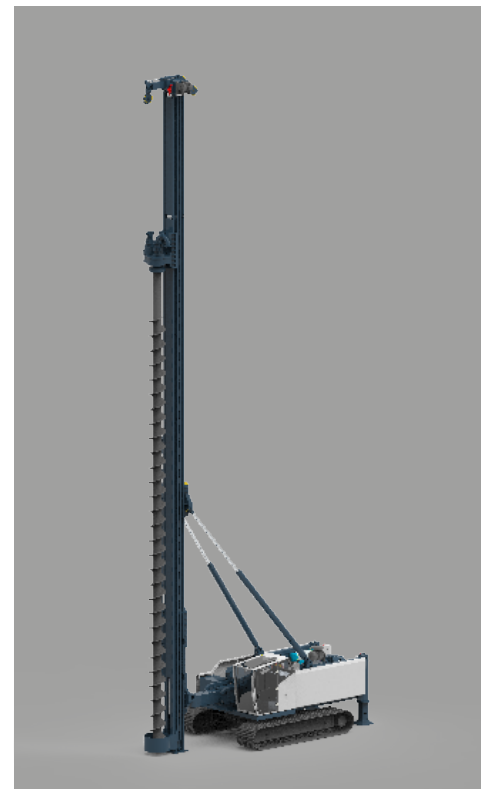

READY FOR THE FUTURE

Van den Heuvel designs, modifies and builds various types of high-quality machines for special applications. VDH is therefore a successful partner in the foundation sector. Production and modification take place entirely in-house, using state-of-the-art equipment, with expertise developed over many years. Everything is taken care of for the customer throughout the process, from the initial request to delivery of the machine, service and maintenance. Custom solutions result in perfect basic machines, which can be adapted to the needs of the customer or project.

